

RoHS compliant

Specification:

Material:
 Contact Material: Brass
 Contact plating: Au or Sn Over 50μ" Ni
 Insulator Material: Black Polyester UL94V-0
 Standard: LCP+30%G.F

Electrical:
 Current rating: 1Amps/contact max.
 Contact resistance: ≤20mΩ/contact
 Insulation resistance: ≥1000MΩ at V=100V
 Withstanding Voltage: 300V AC/minute

Mechanical:
 Mechanical life cycle: min.200
 Operating temperatures: Gold Plated: -55°C to +105°C
 Tin plated: -40°C to +105°C
 Soldering temperature: +245°C, 5s.

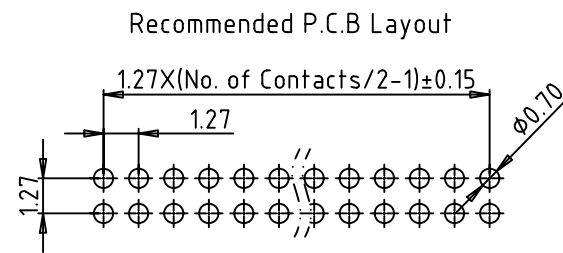
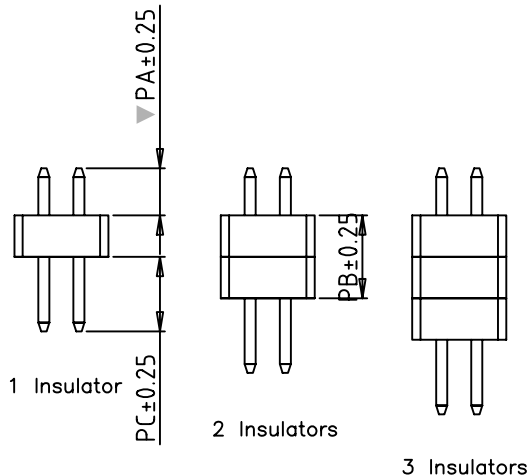
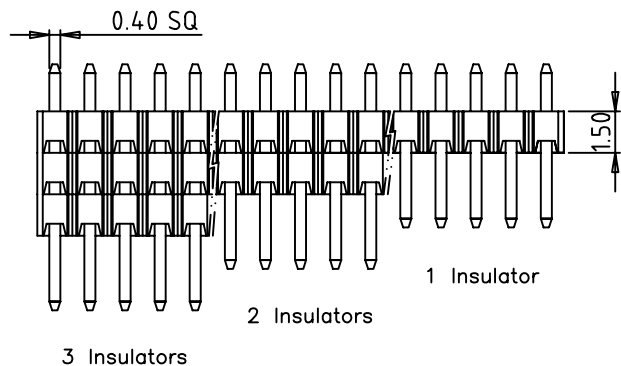
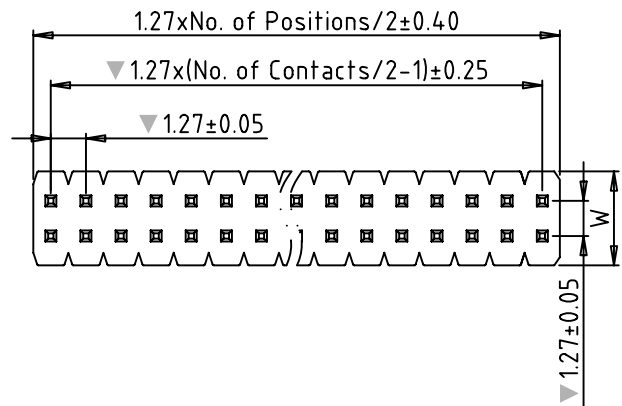

Ordering Information

PH127015D - 2XX X X XX - XXXX - XXXX - XXXX

No. of pins 2*2-2*50
 Plating Option A = Gold Flash B = 3U" Gold C = 5U" Gold E = 15U" Gold T = Tin Z = Special
 Insulator Material Option A = PBT B = PA6T F = LCP Z = Special
 Packing Option A = Tray B = Bag C = Tube Z = Special
 No. of Insulator 01 = 1 Insulator 02 = 2 Insulators 03 = 3 Insulators
 PA Length 0600 = 6.00mm 0900 = 9.00mm 2500 = 25.0mm 1500 = 15.0mm
 PB Length 0900 = 9.00mm 1500 = 15.0mm
 PC Length 0900 = 9.00mm 1500 = 15.0mm

Fortune Star

Fortune Star Technical Co., Limited

TITLE:		1.27mm Pin Header Dual row Dip type					
TOLERANCES UNLESS OTHERWISE SPECIFIED:	DRAWN	Robert	DATE:	2012-03-28	DRAWING NO.:	PH127015D-2XX-XX	
X.XX ±0.25	CHECKED	Jhon	PROJECTION				
X.X ±0.35	APPROVED	Jack	SIZE:	A4	UNIT:	MM	
X. ±0.50			SCALE:	1:1	SHEET:	1/1	
					REV:	A	