



Specification:

Material:
 Contact Material: Brass
 Contact plating: Au or Sn Over 50μ" Ni
 Insulator Material: Black Polyester UL94V-0
 Standard: LCP+30%G.F

Electrical:
 Current rating: 1.5Amps/contact max.
 Contact resistance: ≤20mΩ/contact
 Insulation resistance: ≥1000MΩ at V=100V
 Withstanding Voltage: 450V AC/minute

Mechanical:
 Mechanical life cycle: min.200
 Operating temperatures: -45°C to +105°C
 Soldering temperature: +245°C, 5s.

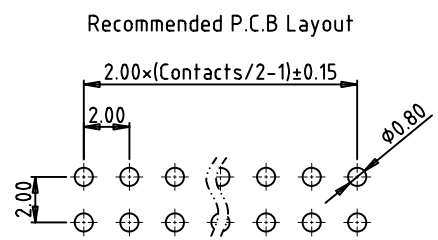
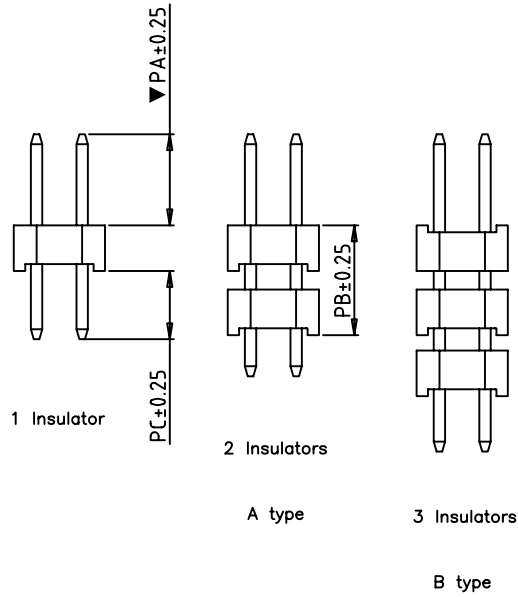
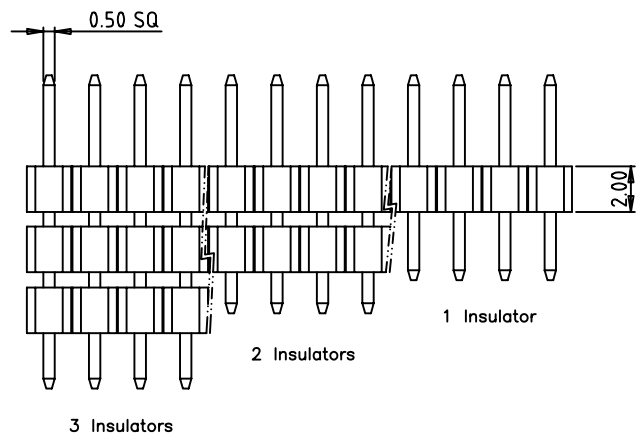
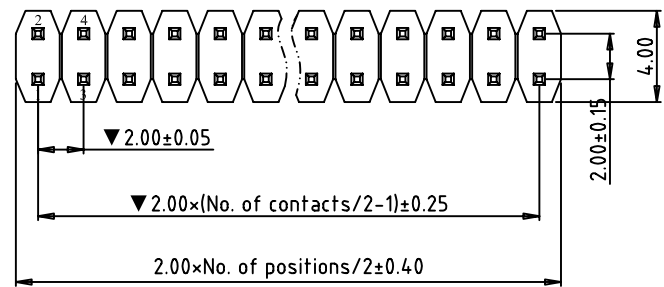

Ordering Information

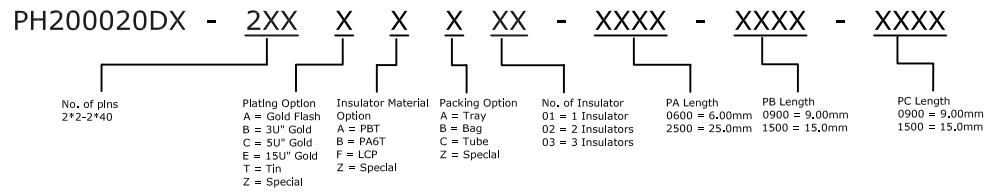

Fortune Star		Fortune Star Technical Co., Limited			
TITLE: 2.00mm Pin Header Dual row Dip type					
TOLERANCES UNLESS OTHERWISE SPECIFIED:	DRAWN	Robert	DATE:	2012-03-28	DRAWING NO.: PH200020DX-2XX-XX
X.XX ±0.25	CHECKED	Jhon	PROJECTION		
X.X ±0.35	APPROVED	Jack	SIZE:	A4	UNIT: MM
X. ±0.50			SCALE:	1:1	SHEET: 1/1 REV: A