

RoHS  
compliant

# Specification:

Material:  
 Contact Material: Brass  
 Contact plating: Au or Sn Over 50μ" Ni  
 Insulator Material: Black Polyester UL94V-0  
 Standard: LCP+30%G.F

Electrical:  
 Current rating: 3.0Amps/contact max.  
 Contact resistance: ≤20mΩ/contact  
 Insulation resistance: ≥1000MΩ at V=100V  
 Withstanding Voltage: 550V AC/minute

Mechanical:  
 Mechanical life cycle: min.200  
 Operating temperatures: -45°C to +105°C  
 Soldering temperature: 245°C, 5s.

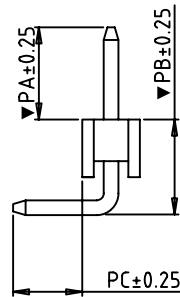
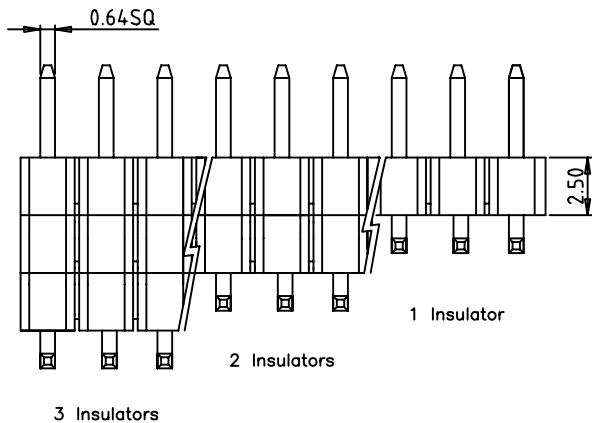
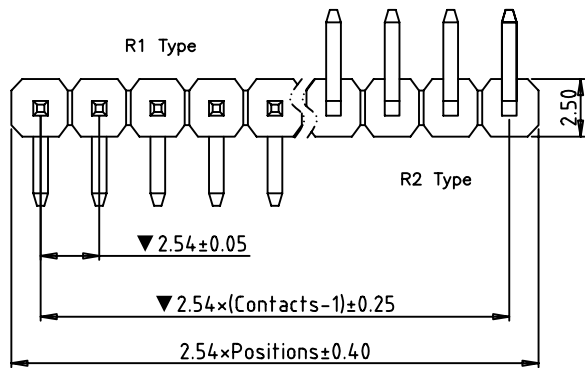

1 Insulator  
R1 type

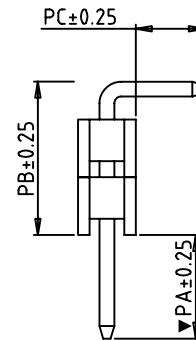

2 Insulators  
R2 type

Recommended P.C.B  
Layout(±0.05)

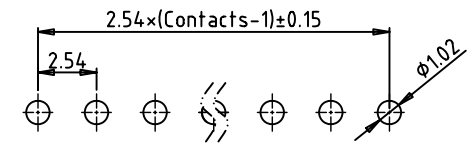

## Ordering Information

PH254025RX - 1XX X X X XX - XXXX - XXXX - XXXX

No. of pins  
1\*1-1\*40

Plating Option  
 A = Gold Flash  
 B = 3U" Gold  
 C = 5U" Gold  
 E = 15U" Gold  
 T = Tin  
 Z = Special

Insulator Material  
 Option  
 A = PBT  
 B = PA6T  
 F = LCP  
 Z = Special

Packing Option  
 A = Tray  
 B = Bag  
 C = Tube  
 Z = Special

No. of Insulator  
 01 = 1 Insulator  
 02 = 2 Insulators  
 03 = 3 Insulators

PA Length  
 0600 = 6.00mm  
 2500 = 25.00mm

PB Length  
 0900 = 9.00mm  
 1500 = 15.0mm

PC Length  
 0900 = 9.00mm  
 1500 = 15.0mm

# Fortune Star

Fortune Star Technical Co., Limited

TITLE: 2.54mm Pin Header Single row Right angle type

TOLERANCES UNLESS OTHERWISE SPECIFIED:		DRAWN	Robert	DATE:	2012-03-28	DRAWING NO.:	PH200020RX-1XX-XX
X.XX	±0.25	CHECKED	Jhon	PROJECTION			
X.X	±0.35	APPROVED	Jack	SIZE:	A4	UNIT:	MM
X.	±0.50			SCALE:	1:1	SHEET:	1/1
						REV:	A