

RoHS compliant

Specification:

Material:
 Contact Material: Brass
 Contact plating: Au or Sn Over 50μ" Ni
 Insulator Material: Black Polyester UL94V-0
 Standard: LCP+30%G.F

Electrical:
 Current rating: 3.0Amps/contact max.
 Contact resistance: ≤20mΩ/contact
 Insulation resistance: ≥1000MΩ at V=100V
 Withstanding Voltage: 550V AC/minute

Mechanical:
 Mechanical life cycle: min.200
 Operating temperatures: -45°C to +105°C
 Soldering temperature: 245°C, 5s.

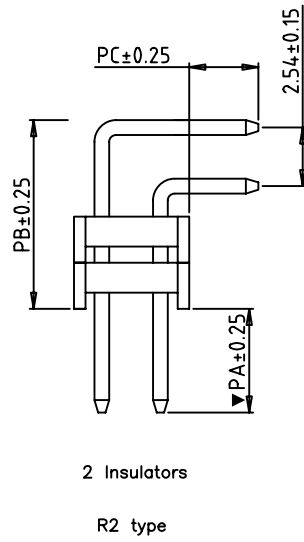
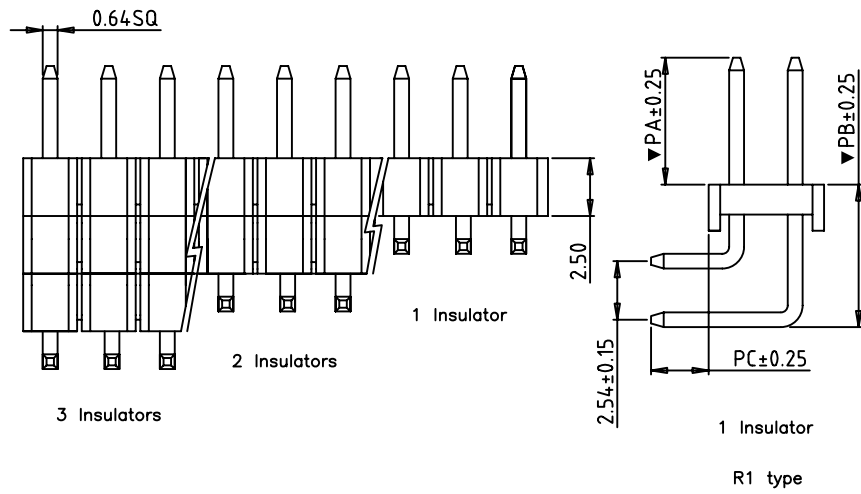
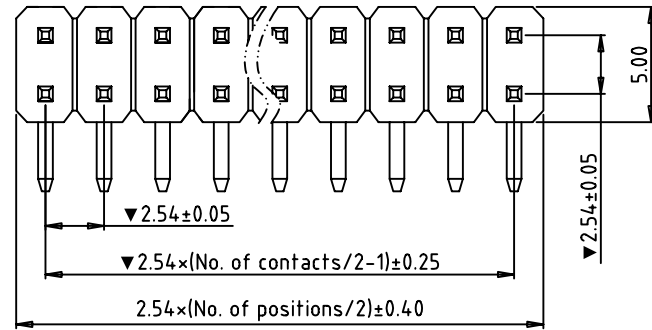

Recommended P.C.B
 Layout(±0.05)

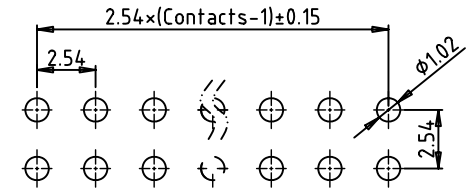

Ordering Information

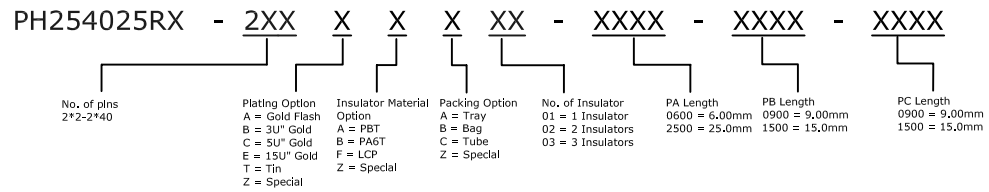

Fortune Star		Fortune Star Technical Co., Limited			
TITLE: 2.54mm Pin Header Dual row Right angle type					
TOLERANCES UNLESS OTHERWISE SPECIFIED:	DRAWN	Robert	DATE:	2012-03-28	DRAWING NO.: PH254025RX-2XX-XX
X.XX ±0.25	CHECKED	Jhon	PROJECTION		
X.X ±0.35	APPROVED	Jack	SIZE: A4	UNIT: MM	SCALE: 1:1
X. ±0.50					SHEET: 1/1 REV: A